

Fall Protection

The purpose of the Fall Protection Program is to establish guidelines to protect all employees engaged in outdoor or indoor work activities that expose them to potential falls from elevations. In particular, this program applies to those staff engaged in work activities which expose them to falls from heights of 4 feet or more.

Each location that requires fall protection presents unique challenges and requires the expertise of a “Qualified Person” to perform an assessment and determine the proper equipment and training required to safely perform the required work. OSHA defines the Qualified Person as “someone who, by possession of a recognized degree, certificate or professional standing, or who by extensive knowledge, training and experience, has successfully demonstrated his ability to solve or resolve problems relating to the subject matter, the work, or the project.” See: Duties and Responsibilities below.

All fall hazards must be identified at work sites that have the potential for elevated work. Once an elevated fall hazard has been recognized, an appropriate control measure must be selected. Priority should be given to elimination of the fall hazard over the use of fall protection equipment. The first line of defense in addressing a fall hazard is to identify and eliminate the hazard. If a fall hazard cannot be eliminated, the second consideration would be to assess the workplace or process and implement an effective permanent means of providing fall protection. If a fall hazard cannot be eliminated and changes to the workplace cannot adequately ensure the prevention of falls, the last line of defense should be to control the fall which would require the use of a fall arrest system.

Any time a worker is at a height of four feet or more, the worker is at risk and needs to be protected. Fall protection must be provided at four feet in general industry, five feet in maritime, and six feet in construction. However, regardless of the fall distance, fall protection must be provided when working over dangerous equipment and machinery. Fall protection must be provided on roofs without 42" high parapet walls or railings. Workers must use fall protection where required.

Contractors and vendors working at or for Florida State University must have an OSHA compliant Fall Protection Program and follow all requirements.

Governing Regulations

Both OSHA General Industry and Construction Fall Protection Standards (29 CFR 1910 and 1926 respectively) can apply for work performed at Florida State University. Even if primarily considered general industry, FSU also performs construction work. Under the General Industry Standard, OSHA defines construction work in [1910.12 \(b\)](#).

It is important to understand the differences between the General Industry and Construction standards. As a best practice, regardless of the work task being performed, the most conservative requirements should be followed. Listed below is a summary of some of the key differences between OSHA’s General Industry and Construction Fall Protection regulations.

Separate OSHA regulations for scaffolding, ladders, and aerial lifts all incorporate fall protection requirements.

TOPIC	CONSTRUCTION INDUSTRY	GENERAL INDUSTRY
-------	-----------------------	------------------

Body Belts	Allowed only as positioning device: 1926.502 (d)	Allowed only as positioning device: 1910.140(d)(3)
Fall Protection	Full program required: 1926.500 – 1926.503	Walking Working Surfaces: 1910.21-1910.30 Personal Fall Protection Systems: 1910.140
Fall Protection Threshold	6 feet: 1926.501 (b)(1)	4 feet: 1910.28(b)(1)(i)

- OSHA [1926.32 Definition of Authorized/Competent/Qualified Persons](#)
- OSHA [1910 Subpart D Walking/Working Surfaces](#)
- OSHA [1910.66 Powered Platforms, Manlifts, and Vehicle-Mounted Work Platforms](#)
- OSHA [1910.140 Personal Fall Protection Systems \(General Industry\)](#)
- OSHA [1926.500/503 Construction Standard for Fall Protection](#)
 - [1926.500 Scope, application and definitions](#)
 - [1926.501 Duty to have fall protection](#)
 - [1926.502 Fall Protection systems criteria and practices](#)
 - [1926.503 Training Requirement](#)

Duties and Responsibilities

Each department or campus entity engaged in work at elevations 4 feet or higher shall designate a person(s) to carry out the duties and responsibilities of the Authorized Person, Competent Person, and Qualified Person. These designated persons will be individuals engaged in activities that include the use of fall protection.

- **Authorized Person:** A person approved or assigned by the department to perform a specific type of duty or duties or to be at a specific location or job site (i.e. building maintenance, roof repair, etc.).
- **Competent Person:** A person capable of identifying existing and predictable hazards in the surroundings or working conditions, which are hazardous or dangerous to employees; a person who has the authorization to take prompt corrective action to eliminate such hazards.
- **Qualified Person:** An individual, who by possession of a recognized degree, certificate, or professional standing; or who by extensive knowledge, training, and experience, has successfully demonstrated his/her ability to solve or resolve problems relating to the subject matter, work, or project.

All the above are defined in [CFR 1926.32](#). The individuals will be identified by the appropriate department heads.

If the department or campus entity is not capable of performing the above activities, a contractor who meets all criteria for the Qualified Person shall be retained to assess what fall protection is required through a hazard assessment. Based on the assessment, the Qualified Person shall recommend engineering, administrative controls, and use of fall protection systems as needed. The Qualified Person shall train the Competent Person (supervisor) and Authorized Person on all aspects of fall protection found in this policy and that are germane to the hazards found in the hazard assessment.

Definitions

Anchor Point: A secure point of attachment for lifelines, lanyards, or deceleration devices. An anchor point must be capable of supporting at least 5000 pounds (3600 pounds if engineered/certified by a qualified person) per person and must be independent of any anchorage being used to support or suspend platforms.

Authorized Person: A person approved or assigned by the department to perform a specific type of duty or duties or to be at a specific location or job site (i.e., building maintenance, roof repair, etc.).

Full Body Harness: Webbing/straps which are secured about an employee's body in a manner that will distribute the fall arrest forces over the thighs, pelvis, waist, chest and shoulders. Having means for attaching it to other components of a personal fall arrest system, preferably at the shoulders and/or middle of the back.

Cage: An enclosure mounted on the side rails of a fixed ladder or fastened to a structure behind the fixed ladder that is designed to surround the climbing space of the ladder. A cage also is called a "cage guard" or "basket guard."

Carabiners: Metal rings with spring-loaded gates, used as connectors. Carabiners must be capable of withstanding a load of 5000 pounds and must be double locking.

Competent Person: A person capable of identifying existing and predictable hazards in the surroundings or working conditions, which are hazardous or dangerous to employees; a person who has the authorization to take prompt corrective action to eliminate such hazards

Connector: A device which is used to couple (connect) parts of the personal fall arrest system together.

Dangerous equipment: Equipment, such as vats, tanks, electrical equipment, machinery, equipment or machinery with protruding parts, or other similar units, that, because of their function or form, may harm an employee who falls into or onto the equipment.

Deceleration Device: Any mechanism, such as a rope grab, rip-stitch lanyard, a specially woven lanyard, tearing or deforming lanyard, automatic self-retracting lifeline/lanyard, etc., which serves to dissipate a substantial amount of energy during a fall arrest.

Deceleration Distance: The additional vertical distance a falling employee travels excluding lifeline elongation and free fall distance, before stopping, from the point at which the deceleration device begins to operate. It is measured as the distance between the location of an employee's body harness attachment point at the moment of activation of the deceleration device during a fall, and the location of that attachment point after the employee comes to a full stop.

Designated area: A distinct portion of a walking-working surface delineated by a warning line in which employees may perform work without additional fall protection.

Extension ladder: A non-selfsupporting portable ladder that is adjustable in length.

Failure: A load refusal, breakage, or separation of component parts. A load refusal is the point at which the ultimate strength of a component or object is exceeded.

Fall hazard: Any condition on a walking-working surface that exposes an employee to a risk of harm from a fall on the same level or to a lower level.

Fall protection: Any equipment, device, or system that prevents an employee from falling from an elevation or mitigates the effect of such a fall.

Fixed ladder: A ladder with rails or individual rungs that is permanently attached to a structure, building, or equipment. Fixed ladders include individual-rung ladders, but not ship stairs, step bolts, or manhole steps.

Free Fall: The act of falling before a personal fall arrest system begins to apply force to arrest the fall.

Free Fall Distance: The vertical displacement of the fall arrest attachment point on the employee's body harness between the onset of the fall and just before the system begins to apply force to arrest the fall. Free fall distance must not exceed 6 feet. This distance excludes deceleration distance and lifeline/lanyard elongation distance.

Total Fall Distance: The maximum vertical change in distance from the bottom of an individual's feet at the onset of a fall, to the position of the feet after the fall is arrested. This includes the free fall distance and the deceleration distance.

Grab bar: An individual horizontal or vertical handhold installed to provide access above the height of the ladder.

Guardrail System: A barrier erected to prevent employees from falling to lower levels. This system includes a toeboard, midrail, and toprail able to withstand 200 pounds of force applied in any direction.

Handrail: A rail used to provide employees with a handhold for support.

Hole: A gap or open space in a floor, roof, horizontal walking-working surface, or similar surface that is at least 2 inches (5 cm) in its least dimension.

Ladder: A device with rungs, steps, or cleats used to gain access to a different elevation.

Ladder safety system: A system designed to eliminate or reduce the possibility of falling from a ladder. A ladder safety system usually consists of a carrier, safety sleeve, lanyard, connectors, and body harness. Cages and wells are not ladder safety systems.

Lanyard: A flexible line of rope or strap that has self-locking snaphook connectors at each end for connecting to body harnesses, deceleration devices, and anchor points.

Leading Edge: The edge of a floor, roof, or other walking/working surface, which changes location as additional floor, roof, etc., is placed or constructed. A leading edge is considered an unprotected side or edge when not under active construction.

Lifeline: A component consisting of a flexible line for connection to an anchorage at one end to hang vertically (vertical lifeline), or for connection to anchorages at both ends to stretch horizontally (horizontal lifeline). This serves as a means for connecting other components of a personal fall arrest system to the anchorage.

Low Slope Roof: A roof having a slope of less than or equal to 4 in 12 (vertical to horizontal). A roof with approximately a 19.5 degree slope or less.

Overhand bricklaying: The process of laying bricks and masonry so that the surface of the wall is on the opposite side of the wall from the mason, requiring the mason to lean over the wall to complete the work. It includes mason tending and electrical installation incorporated into the brick wall during the overhand bricklaying process.

Personal Fall Arrest System: A system used to arrest (catch) an employee in a fall from a working level. It consists of an anchorage location, connectors, a body harness, and may include a lanyard, deceleration device, lifeline, or any combination of the before-mentioned items.

Personal fall protection system: A system (including all components) an employer uses to provide protection from falling or to safely arrest an employee's fall if one occurs. Examples of personal fall protection systems include personal fall arrest systems, positioning systems, and travel restraint systems.

Platform: A walking-working surface that is elevated above the surrounding area.

Portable ladder: means a ladder that can readily be moved or carried, and usually consists of side rails joined at intervals by steps, rungs, or cleats.

Positioning Device System: means a full body harness system rigged to allow an employee to be supported on an elevated vertical surface, such as a wall, and work with both hands free while leaning.

Qualified Person: An individual, who by possession of a recognized degree, certificate, or professional standing; or who by extensive knowledge, training, and experience, has successfully demonstrated his/her ability to solve or resolve problems relating to the subject matter, work, or project.

Rope Grab: A deceleration device, which travels on a lifeline and automatically, by friction, engages the lifeline and locks to arrest the fall of an employee.

Roof Work: The hoisting, storage, installation, repair, and removal of materials or equipment on the roof.

Safety Monitoring System: A safety system in which a competent person is responsible for recognizing and warning employees of fall hazards. All other fall protection systems must be deemed "infeasible" (through infeasibility study/review) to select/use a safety monitoring system.

Snaphook: A connector comprised of a hook-shaped member with a closed keeper which may be opened to permit the hook to receive an object and when released, automatically closes to retain the object. Snaphooks must be self-closing with a self-locking keeper which remains closed and locked until unlocked and pressed open for connection or disconnection, thus preventing the opportunity for the object to "rollout" of the snaphook.

Stairway (stairs): Risers and treads that connect one level with another, and includes any landings and platforms in between those levels. Stairways include standard, spiral, alternating tread-type, and ship stairs.

Steep Slope Roof: A roof having a slope greater than 4 in 12 (vertical to horizontal). A roof with a slope greater than 19.5 degrees.

Toeboard: A low protective barrier that will prevent the fall of materials and equipment to lower levels, usually 4 inches or greater in height.

Unprotected Sides and Edges: Any side or edge of a walking or working surface (e.g., floor, roof, ramp, runway, etc.) where there is no guardrail at least 39 inches high.

Warning Line System: A barrier erected on a roof to warn employees that they are approaching an unprotected roof side or edge; such a barrier designates an area in which work can be conducted without the use of guardrails, personal fall arrest systems, or safety nets to protect employees in the area. This system will be utilized on any roof greater than 50 feet wide and in conjunction with a safety monitor only where the other forms of fall protection have been deemed infeasible to use.

Program Elements

Hazard Identification and Fall Protection Assessment Plan

A well-conceived fall protection program begins with identification of all fall hazards in the workplace. As a general rule, any time a worker is at a height greater than 4 feet, a fall hazard exists. Where a fall hazard exists, there are two acceptable options: (1) eliminate the hazard, or (2) provide protection against it. It is best to totally eliminate the hazard. Since that is often not possible, other measures such as using personal protection equipment (PPE) are required.

When fall hazards cannot be eliminated and the use of a guardrail, fall-protection system, and distance cannot be applied, then administrative controls must be used. When necessary, hazards may be managed with administrative controls by using a Fall Prevention Hazard Assessment Plan that details special training and work plans. These plans may only be used for leading edge work or precast concrete work and only if conventional fall protection equipment cannot be used or creates a greater hazard.

Fall Prevention Assessment Plans shall meet the following requirements:

- The workplace will be assessed before each assigned job for potential fall hazards. When administrative controls are used, the [Fall Protection Hazard Assessment Plan \(Appendix A\)](#) will be completed by a Qualified Person.
- The plan will explain the measures that will be taken to reduce or eliminate the fall hazard for workers who cannot be provided with protection from the conventional fall protection systems. For example, the extent to which scaffolds, ladders, and vehicle-mounted work platforms can be used to provide a safer working surface and reduce the hazard of falling.
- Identify each location where conventional fall protection methods cannot be used. These locations must be classified as Controlled Access Zones.
- If applicable, the plan will explain why the use of conventional fall protection systems, such as guardrail systems, personal fall arrest systems, restraint or positioning device systems are infeasible or why their use would create a greater hazard.
- Maintain up-to-date records with any changes approved by a Qualified Person.
- A copy of the [Fall Protection Hazard Assessment Plan \(Appendix A\)](#) with all approved changes must be available at the jobsite.
- The Fall Prevention Hazard Assessment Plan shall be reviewed and signed by the Competent Person.
- Once the Fall Prevention Hazard Assessment Plan form is completed, the plan should be retained. EH&S will audit periodically that assessment plans are being completed correctly.

Written Fall Protection Plan

Once fall hazards are identified, a written plan will be developed specifying how each hazard is addressed. If standardized safe work practices and operating procedures can eliminate the hazard, then such procedures should be specified. Where hazard elimination is impossible, the plan should state what fall protection measures are to be used, how they are to be used, and who is responsible for overall supervision and training. This plan should cover all elements and needs to be clearly conveyed and understood by all participants.

Fall Protection for Specific Tasks

Roof Work

- Activities on flat roofs, low slope roofs, and high sloped roofs with unprotected sides and edges 6 feet or more above lower levels shall be protected from falls by a guardrail system, restraint system, positioning device system, and/or a personal fall arrest system only.
- Materials and equipment shall not be stored within 6 feet of a roof edge unless guardrails are erected at the edge and materials piled, grouped, or stacked near a roof edge must be stable, self-supporting, and secured.
- If conventional fall protection systems cannot be used, a Written Fall Protection Plan must be developed and followed. [Appendix A](#) and [Appendix I](#) are used to assist in this task.

Excavation Work

- Each employee at the edge of an excavation 6 feet or more deep shall be protected from falling by guardrail systems, fences, barricades, or covers.
- Where walkways are provided to permit employees to cross over excavations, guardrails are required on the walkway if the fall would be 6 feet or more in depth and the excavation is wider than 30 inches at the top.
- A stairway, ladder, ramp, or other safe means of egress shall be located in excavations that are 4 feet or more in depth so no more than 25 feet of lateral travel is required for employees to exit.

Overhand Bricklaying

- Each employee performing overhand bricklaying 6 feet or more above lower levels and reaching more than 10 inches below the level of the walking/working surface shall be protected by guardrail systems, restraint systems, or positioning device systems.

Fall Protection Rescue Plan

Fall protection rescue should take as little time as possible to bring a fallen worker to safety. When a fall occurs, any number of factors can create challenges to the effective rescue of the victim. Weather conditions, physical obstacles, and the condition of the victim can consume time and create hindrances for rescue personnel. All rescue plans ([Appendix B](#)) should be reviewed by the employees doing the work to ensure that the procedures are manageable and realistic.

If a positioning device system and/or fall-arrest system is not used then the Fall Protection Hazard Assessment Plan form ([Appendix A](#)) must be used. All employees involved with any part of the fall protection system must be informed of the plan.

Rescue guidelines to consider:

- Rescue suspended workers as quickly as possible.
- Be aware of the potentially life threatening risks of orthostatic intolerance and suspension trauma.
- Be aware of signs and symptoms of orthostatic intolerance.
- Be aware suspended workers who are unconscious or have head injuries are particularly at risk for orthostatic intolerance.
- Be aware of the factors that can increase the risk of suspension trauma.

For more information on orthostatic intolerance go to: <https://www.osha.gov/dts/shib/shib032404.html>

Fall Protection Selection and Work Practices

The Competent Person must know the types of fall protection products that are available and decide which would be most suitable for the workplace. Because all work environments differ, it is impossible for the manufacturer to determine exactly which fall protection products will provide maximum protection for each job. By understanding how fall protection products operate and knowing the differences in product functions, the Competent Person can select products that are best suited for their workers.

Fall Protection Work Practices

A preferred fall protection hierarchy shall be used when choosing methods to eliminate or control fall hazards.

The preferred hierarchy is:

- Elimination or Substitution: Remove the hazard. (Requires Qualified Person or Design Professional)
- Passive Fall Protection: Isolate or separate hazard from workers. (Requires Qualified Person or Design Professional)
- Fall Restraint: Prevent the person(s) from reaching the fall hazard. (Requires Qualified Person)
- Fall Arrest: Attach a person to a system designed to stop a fall after it has begun. (Requires Qualified Person)
- Administrative Controls: Establish work practices or procedures to warn an authorized person to avoid approaching a fall hazard. Use only for low slope roofs. (Requires Competent Person)

Option 1 – Guardrail System

If elimination or substitution is not possible or practical, the first option is to use a guardrail system to protect workers from falls. When utilized, a guardrail system shall meet the following criteria:

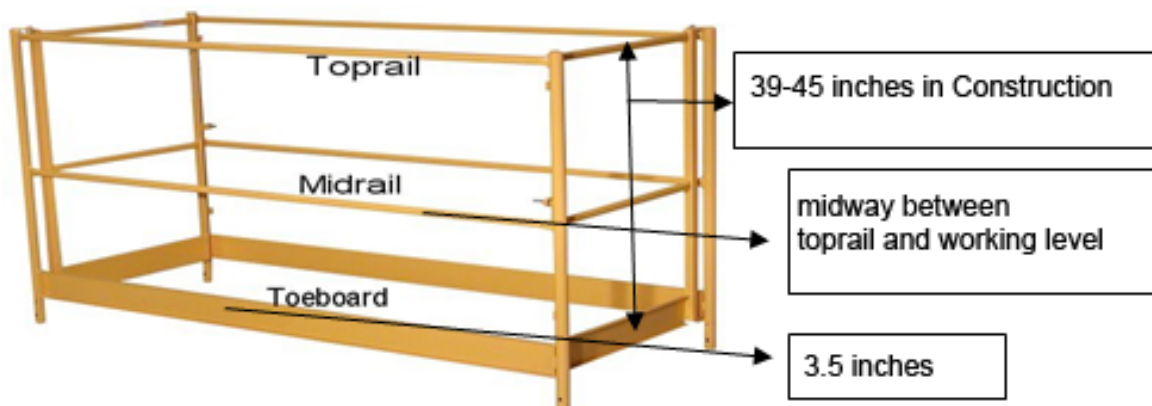

Toprails

- Must be 42 inches plus or minus 3 inches above the walking/working level. (Construction & General Industry)

- Must be capable of withstanding a force of at least 200 pounds (applied within 2 inches of the top edge in any outward or downward direction).
- Must be inspected as frequently as necessary to ensure strength and stability.
- Must protect workers from punctures or lacerations and made to prevent clothing from snagging.

Midrails

- Must be installed at a height midway between the top edge of the guardrail system and the walking/working level.
- Must be capable of withstanding a force of at least 150 pounds (applied in any downward or outward direction).

Toeboards

- Are always required in General Industry but only required in Construction Industry if the area below cannot be protected from people entering.
- Shall be 4 inches nominal in vertical height from its top edge to the level of the floor, platform, runway, or ramp.
- Shall be capable of withstanding, without failure, a force of at least 50 pounds applied in any downward or outward direction at any point along the toeboard.
- Shall be securely fastened in place and with not more than 1/4-inch clearance above floor level.
- Where tools, equipment, or materials are piled higher than the top edge of a toeboard, paneling or screening shall be erected from the walking/working surface or toeboard to the top of a guardrail system's top rail or midrail, for a distance sufficient to protect employees below.

Option 2 - Fall Protection Restraint System

The second option is to use a Restraint System to protect workers from falls. A restraint system is rigged to allow workers to move only as far as the sides of the work area and prevents the wearer from reaching a fall hazard.

A restraint is a full-body harness, lanyard, cable, or rope with a rope grab at a predetermined length, which is connected to the anchor and the user, and is shorter than the distance to the unprotected edge. The system will let the employee walk around and be able to reach the edge but will not let the employee fall off the edge.

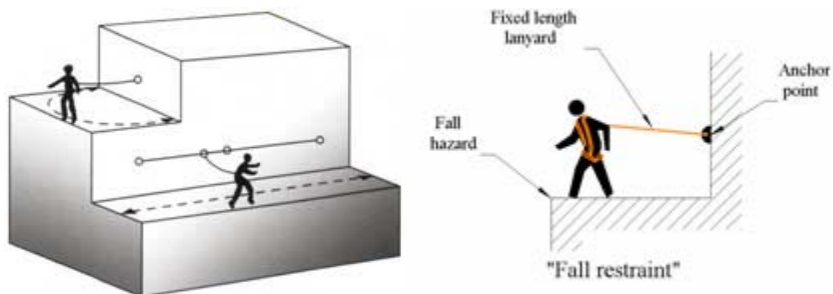

When utilized, a restraint system shall meet the following criteria:

- Must be visually inspected by the trained user prior to using.

- Physically prevent the user from reaching an unprotected edge and/or fall from or through the structure. See above diagram.
- Protection shall be rigged to allow the movement of employees only as far as the sides of the working level or working area.
- The anchor point must have an ultimate load capacity in any direction in which a load may be applied of at least 800 lbs or a structure that cannot be moved or pulled over by the employee.
- The anchor point for the lanyard may be placed at foot level, provided there is no likelihood of damage to the equipment.
- Lanyards or rope grab shall be secured to a substantial member of the structure.
- All employees must be trained.
- A restraint line is not necessarily designed to withstand forces resulting from a fall, therefore the rope or cable does not have to be (5,000 lbs) rated.
- No provisions need to be made for rescue.

Option 3 - Positioning Device System

A positioning device system consists of an anchor point, energy shock absorber, and full-body harness and a device that shall be rigged such that an employee cannot free fall more than 2 feet.

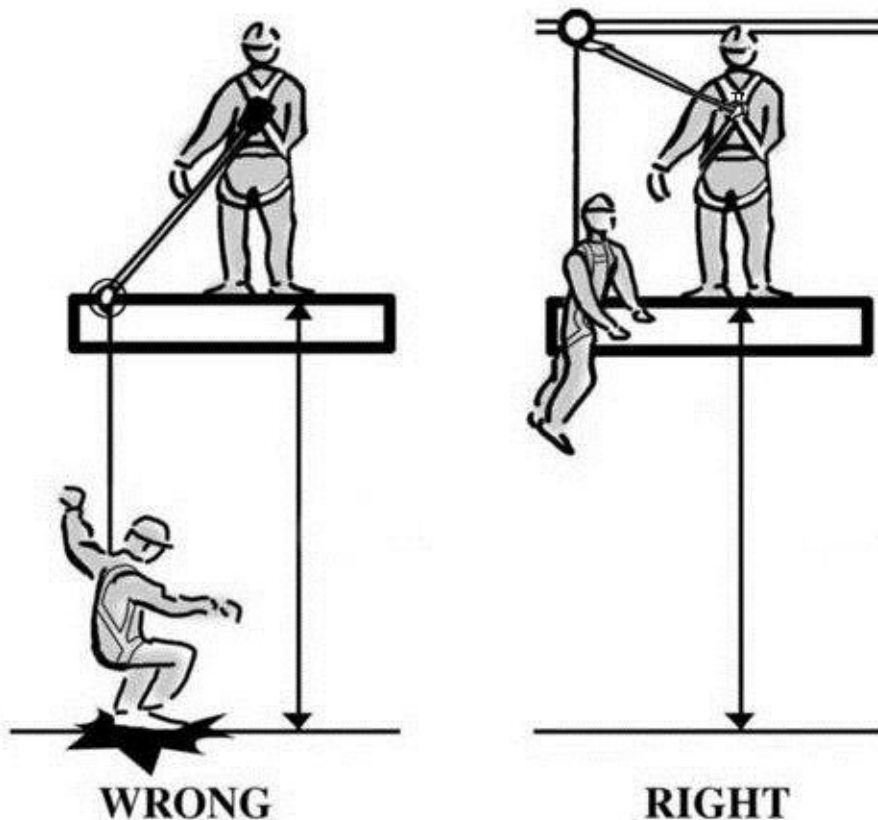

When utilized, a positioning device system shall meet the following criteria:

- Must be visually inspected by the trained user prior to using.

- Must only be used in a vertical position.
- Provisions must be made for rescue with the Tallahassee Fire Department. The following form must be completed by the competent person and delivered to the Tallahassee Fire Department prior to commencement of the activity. Rescue Plan ([Appendix B](#))
- Anchors used to attach the positioning devices shall be capable of supporting at least 3,000 pounds per person attached.
- Connecting assemblies shall have a minimum tensile strength of 5,000 pounds.
- Positioning devices shall be rigged such that an employee cannot free fall more than 2 feet.
- The fixed anchor shall be rigid when force is applied.
- A single double locking lanyard shall have one end attached to a fixed anchor and the other end connected to a body.
- A double locking lanyard shall be used to maintain a 100% tie-off when moving.
- A retractable lifeline may be considered when working in areas such as on roofs and scaffolds, or in tanks, towers, vessels, or manholes. The retractable lifelines must automatically limit free fall distance to 2 feet.

Option 4 - Personal Fall Arrest System

When fall hazards cannot be eliminated through any other means and a guardrail, restraint system, or positioning device is not feasible, then a Personal Fall Arrest System can be used to control falls.

A Personal Fall Arrest System consists of: an anchor strap (1), anchor point (tie-off) (2), double-locking lanyard, energy shock absorber (3), and full-body harness (4).

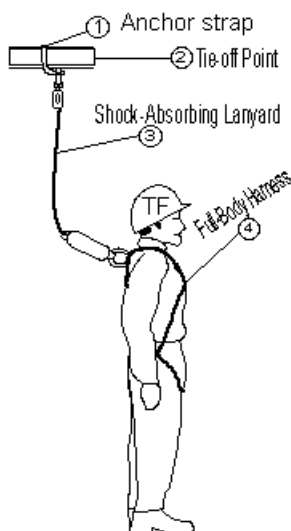

When utilized, a Personal Fall Arrest System shall meet the following criteria:

- All users must be trained.
- Provisions must be made for rescue with the Tallahassee Fire Department. The following form must be completed by the competent person and delivered to the Tallahassee Fire Department prior to commencement of the activity. Rescue Plan ([Appendix B](#))

- Anchors used to attach a Personal Fall Arrest System shall be capable of supporting at least 5,000 pounds per person attached.
- Must be rigged so that employees can neither free fall more than 6 feet or contact any lower level below.
- Must be inspected by the user prior to each use for wear, damage, or other deterioration.
- Any defective components must be removed from service.
- If anchors are installed, they shall be designed under the supervision of a Qualified Person.
- Must be inspected annually by a Competent Person.

Option 5 - Distance Protection/Designated Area (Maintenance work ONLY)

The fifth option is to use distance to protect workers from falls. This is determined by how close the employees can work near the unprotected sides and edges and is only approved for maintenance work.

Distance Protection shall meet the following criteria:

- The area where the employee is working shall be erected not less than 6 feet from the roof edge for work or not less than 15 feet from other work.
- The work must be of a temporary nature, such as maintenance on roof top equipment.
- The working surface must be free of rain and ice and have a surface that does not pose a slipping hazard.
- The designated area surface areas shall be as flat as possible and cannot have a slope of 10 degrees or more.
- The designated area shall consist of an area surrounded by a rope, wire, or chain and supporting stanchions erected in accordance with these criteria:
 - *Strength criteria:*
 - Stanchions shall be capable of resisting, without tipping over, a force of at least 16 pounds applied horizontally against the stanchion in the direction of the unprotected side or edge.
 - Rope, wire, or chain shall have a minimum breaking or tensile strength of 200 pounds, and after being attached to the stanchions, shall be capable of supporting, without breaking, the loads applied to the stanchions.
 - Rope, wire, or chain shall be attached at each stanchion in such a way that pulling on one section of the line between stanchions will not result in slack being taken up in adjacent sections before the stanchion tips over.
 - *Height criteria:*
 - Rope, wire, or chain shall be installed in such a manner that its lowest point (including sag) is no less than 34 inches and no more than 39 inches from the work surface.
 - *Visibility criteria:*
 - Rope, wire, or chain forming the designated area shall be clearly visible from any unobstructed location and

- Is clearly visible from a distance of 25 feet away and anywhere within the designated area.
- *Location criteria:*
 - Stanchions shall be erected as close to the work area as is permitted by the task.
- Access to the designated area shall have a clear path, formed by two lines, attached to stanchions, which meet the strength, height, and visibility requirements of this paragraph.
- No provisions need to be made for rescue.

Inspection and Maintenance

To maintain their service life and high performance, fall protection equipment shall be inspected. Visual inspection of all fall protection equipment being used shall be performed by the trained wearer before each use.

Inspecting the Personal Fall Arrest System prior to using:

- All personal fall arrest systems such as full body harnesses, lanyards/shock absorbing lanyards, hooks/carabiners, tie-off adapters/anchor plates, self-retracting lifelines, and temporary guardrails must be inspected.
 - Prior to using the personal fall arrest system, the trained user must inspect each piece of equipment used.
 - Appendices C through H as applicable can be used as a reference
 - Any defective components must be removed from service and reported to your supervisor. Turn the equipment into Environmental Health and Safety for disposal.

Inspecting the Personal Fall Arrest System Annually:

- A trained competent person will complete an annual inspection of all the Personal Fall Arrest System equipment and documentation will be maintained at each individual department and be available for Environmental Health and Safety to review.
- Every year the equipment will be logged and color coded.
- Appendices C through H as applicable will be used to log each piece of the Personal Fall Arrest System equipment.
- The Inspection Checklist/Log (Appendices C through H as applicable) must be used to log each piece of the Personal Fall Arrest System equipment and will be used for tracking inventory.
- If equipment is exposed to a fall, remove equipment from service immediately, tag the equipment, and dispose of the equipment.

Maintenance and Storage of Fall Protection Equipment:

- Always follow the manufacturer's guidelines.
- Hang equipment in a cool, dry location in a manner that retains its shape.
- Clean with a mild, nonabrasive soap and hang to dry.
- Never force dry or use strong detergents in cleaning.

- Never store equipment near excessive heat, chemicals, moisture, or sunlight.
- Never store in an area with exposures to fumes or corrosive elements.
- Avoid dirt or other types of build-up on equipment.
- Never use this equipment for any purpose other than personal fall arrest.
- Never store the Personal Fall Arrest Equipment in the bottom of a toolbox, on the ground, or outdoors exposed to the elements (i.e. sun, rain, etc.).

Training

All workers must be trained in the proper use of fall protection equipment before using any fall protection products. Workers must be able to identify potential fall hazards, determine which products to use in specific work environments, demonstrate proper anchoring procedures, etc. Employees must also learn inspection and maintenance procedures and the proper wearing of fall protection equipment.

Initial Training

The purpose of this section is to establish a continuous training schedule and to outline the types of training required by personnel. Florida State University will provide training to ensure that the purpose, function, and proper use of all fall protection is understood by employees, and that the knowledge and skills required for the safe application and usage is acquired by employees. This section applies to all University personnel that may be required to use fall protection. Upon completion of the training, individuals will, at a minimum:

- Become familiar with different types of fall protection equipment appropriate for use.
- Be able to identify fall hazards associated with the work locations and the work to be completed.
- Understand the procedures for removal of protection devices from service for repair or replacement.
- Know how to preserve and keep equipment in working order.
- Understand equipment inspection requirements.
- Know the procedures of donning and doffing equipment.
- Understand the equipment strengths and limitations.
- Recognize some other options such as safety nets, guardrails, controlled access zones, and safety monitoring system.
- All other employees whose work operations are or may be in an area where fall protection devices may be utilized, will be instructed to an awareness level concerning hazards associated with fall protection operations.

Refresher Training

Refresher training will be conducted if a need is identified through annual self-assessment or when the following conditions are met, whichever event occurs sooner.

- Change in equipment or hazards. Retraining will be provided for all authorized and affected employees whenever there is a change in the type of fall protection equipment used, or when a known hazard is added to the work environment which affects the fall prevention program.

- Inadequacies in employee knowledge. Additional retraining will also be conducted whenever a periodic inspection reveals, or whenever this employer has reason to believe, that there are deviations from, or inadequacies in, employee's knowledge or use of fall protection equipment or procedures.
- If the fall protection procedure fails.
- Proficiency and Procedures. The retraining will reestablish employee proficiency and introduce new or revised methods and procedures, as necessary.

Certification

All training shall be documented and training records made available for audits and self-assessments. Attendance records shall be kept with sign-in sheets showing the name of attendees, date, instructor, and type of training. These records shall be sent to EH&S and will be stored electronically.

Records and Document Control

All Fall Hazard Assessment forms ([Appendix A](#)) and the fall protection rescue form ([Appendix B](#)) will be stored at each individual department. The fall protection equipment inspection forms (Appendices C through H as applicable) will be kept at each individual department. All documents must be available for EH&S to review periodically.

Additional Fall Protection Equipment

Scaffold

- Guardrails or a fall-protection system at 6 feet will be required at all times while erecting and dismantling scaffolding unless the competent person can prove that fall protection is infeasible.
- Once erected, scaffolding, 6 feet or more in height that employees are working off of, shall be required to have a guardrail or a fall-protection system.
- The manufacturer's guidelines pertaining to guardrail or a fall-protection system may vary. Scaffold may need fall protection at lower heights.
- Where tools, equipment, or materials are piled higher than the top edge of a toeboard, paneling or screening shall be erected from the walking/working surface to the top of the guardrail system's top rail, or midrail, to protect employees below.
- The scaffold must be properly inspected by a trained Competent Person at the beginning of the shift before the scaffold can be accessed and if the scaffold integrity is changed.
- The inspection tags must be hanging by the scaffolding access. Examples of Scaffold Tags are available in [Appendix H](#).
- If scaffold is used for a fall protection catch platform then:
 - The platform shall be placed where the employee cannot fall more than 6 feet (construction) or 4 feet (general industry) to the scaffold platform.
 - Netting and a guardrail system shall be used on the scaffold platform.
 - The platform shall be completely planked.
 - All employees must be trained before accessing scaffold.

Boatswain's Chair

The device is used to suspend a person from a rope in a chair in order to perform work aloft.

- The use of a full body harness must also be used and connected independent of the boatswain's chair device, and its support system, so that any failure of the boatswain's chair, support line, or anchor system will not affect the ability of the fall arrest system to operate and quickly stop the fall.
- When attaching the personal fall arrest system it shall be independent of any anchor being used to support or suspend the boatswain's chair.
- The equipment must be inspected each day before use with emphasis on providing tiebacks when counterweights, cornice hooks, or similar non-permanent anchor systems are used.
- Employees must be trained in the use.
- All lines installed (such as by using knots, swages, or eye splices) when rigging descent control devices shall be capable of sustaining a minimal tensile load of 5,000 pounds.
- Provisions must be made for rescue with the Tallahassee Fire Department. The Fall Protection Rescue Plan ([Appendix B](#)) must be completed by the Competent Person and delivered to the Tallahassee Fire Department prior to commencement of the activity.
- Ropes must be effectively padded where they contact edges of the building, anchor, obstructions, or other surfaces which might cut or weaken the rope.
- When suspension heights exceed 130 feet and where rigging must be suspended by hand, mechanical means shall be provided for raising and lowering lines (wire rope, fiber, and cable) when the entire line's weight exceeds 55 pounds.



Articulating Boom Lift

This type of lift consists of a number of jointed sections which can be controlled to extend the lift in a number of different directions, which can often include 'up and over' applications.

- A full body harness attached to a proper anchor shall be required when operating the lift at any height.
- All gates or chains must be closed or latched, and secured, when lift is being used.
- If you get out of the lift (basket) at heights, you must connect to a separate rated anchor point (not the lift).
- All employees must be trained before using an articulating boom lift.
- All controls and warning stickers in or on the lift must be legible.



Scissor Lift

This type of lift consists of a mechanical-type platform which only moves in a vertical plane (straight up and down).

- A full body harness attached to a proper anchor shall be required when operating the lift at any height if the Scissor Lift is supplied with a proper restraint anchor.
- All gates or chains must be closed or latched, and secured, when lift is being used.
- Feet must remain on the floor at all times (no standing on rails).
- No ladders are permitted on the scissor lift platform.
- All employees must be trained before using a scissor lift.
- All controls and warning stickers in or on the lift must be legible.



Ladders

General requirements for ladders:

- All ladders must be clearly identified with the type and capacity of the ladder.
 - Type I-A 300 pounds (extra heavy duty)
 - Type I 250 pounds (heavy duty)
 - Type II 225 pounds (medium duty)
 - Type III 200 pounds (light duty) type III ladders are NOT allowed for use at Florida State University.
- The ladder shall be maintained in good condition at all times, the joint between the steps and side rails shall be tight, all hardware and fittings securely attached, and the movable parts shall operate freely without binding or undue play.
- Ladders should not be used to gain access to a roof or platform unless the top of the ladder extends 3 feet above the point of support, at eave, gutter, or roofline, and secured to prevent accidental movement.
- The ladder shall be inspected frequently, and those which have developed defects shall be withdrawn from service for repair and tagged or marked as "Do Not Use", and reported to your supervisor. If the ladder cannot be repaired, the ladder must be destroyed and disposed of.
- The feet of the ladder and other auxiliary equipment shall be kept in good condition to ensure proper performance.

- Do not lean outside of the ladder rails. If the center line of the body cannot be maintained between the ladder rails while working on a ladder, then a personal fall arrest system shall be required.
- When climbing, always Use the "3-Point Rule": at least two hands and one foot, or two feet and one hand, should be in contact with the ladder at all times.

Stepladders

A stepladder is defined as an A-shaped, self-supporting ladder which has two sets of hinged supports. The supports meet at the top and are held together by collapsible hinges.

- A stepladder longer than 20 feet shall not be used.
- Do not stand on top 2 steps of a stepladder.
- Stepladders must be used in the locked-open position.

Extension Ladder

An extension ladder is a non-self-supporting ground ladder that consists of two or more sections traveling in guides, brackets, or the equivalent arranged so as to allow length adjustment.

- A two-section extension ladder longer than 60 feet shall not be used.
- To ensure a safe position, the horizontal distance from the support structure to the foot of the ladder is 1/4 the working length of the ladder.
- The extension ladder shall be secure from accidental movement or held in position.
- The extension ladder shall not be used in a horizontal position as platforms or runways.

Fixed Ladder

A fixed ladder is a vertical ladder mounted permanently to a structure.

- Metal ladders and appurtenances shall be painted or otherwise treated to resist corrosion and rusting when location demands.
- Fixed ladders that extend more than 24 feet above a lower level:
 - Fixed ladder installed before November 19, 2018 is equipped with a personal fall arrest system, ladder safety system, cage, or well;
 - Each fixed ladder installed on and after November 19, 2018, is equipped with a personal fall arrest system or a ladder safety system;
 - When a fixed ladder, cage, or well, or any portion of a section thereof, is replaced, a personal fall arrest system or ladder safety system is installed in at least that section of the fixed ladder, cage, or well where the replacement is located; and
 - On and after November 18, 2036, all fixed ladders are equipped with a personal fall arrest system or a ladder safety system.
- When ladders are used to ascend to heights exceeding 24 feet landing platforms shall be provided for each 30 feet of height or fraction thereof, except that, where no cage, well, or ladder safety device is provided, landing platforms shall be provided for each 24 feet of height or fraction thereof.

- Ladder safety devices may be used on tower, water tank, and chimney ladders over 24 feet in unbroken length in lieu of cage protection. No landing platform is required in these cases. All ladder safety devices such as those that incorporate full body harness, friction brakes, and sliding attachments shall meet the design requirements of the ladders which they serve.

Retractable Lifelines

- A Retractable Lifeline is a fall arrest device used in conjunction with other components of a Fall Arrest System.
- Retractable Lifelines should be used by only one person at a time.
- Retractable Lifelines must be properly inspected and maintained. A Self Retracting Lifeline Inspection Checklist/Log is available in [Appendix C](#).
- Retractable Lifelines must be installed properly to automatically stop a person's descent in a short distance after the onset of an accidental fall.
- If the free fall distance is 2 feet or less, the lifeline anchor point shall be capable of sustaining a minimum tensile load of 3,000 pounds.
- If the free fall distance is more than 2 feet, then the lifeline anchor point shall be capable of sustaining a minimum tensile load of 5,000 pounds.

Dee-rings, Carabiners, and Snaphooks

- Dee-rings, Carabiners, and Snaphooks must have a minimum tensile strength of 5,000 pounds.
- Dee-rings and Snaphooks shall be double locking.

Dee-rings and Snaphooks must be properly inspected and maintained. A Dee-Rings, Hooks, and Carbiners Checklist is available in [Appendix D](#).

- Unless the Dee-ring, Carabiner, or Snaphook is designed for the following connections, they shall not be connected:
 - directly to webbing, rope, or wire rope
 - to each other
 - to a Dee-ring to which another snaphook or other connector is attached
 - to a horizontal lifeline
 - to any object incompatible in shape or dimension relative to the snaphook, thereby causing the connected object to depress the snaphook keeper and release unintentionally

Figure 1 - Snap Hooks and Carabiners

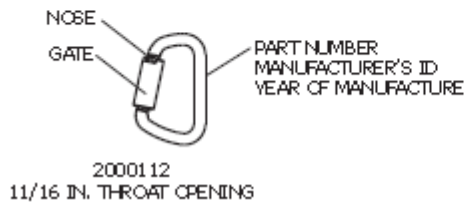
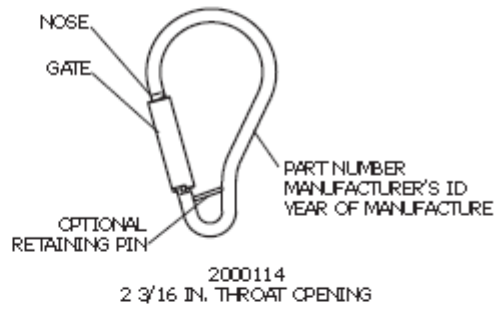
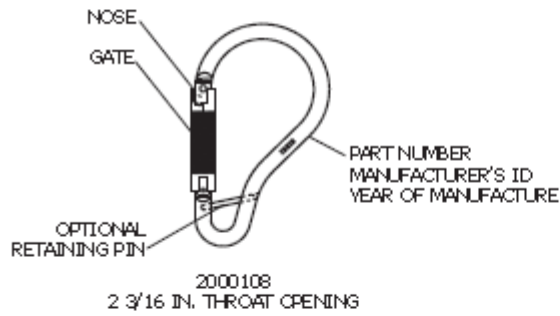
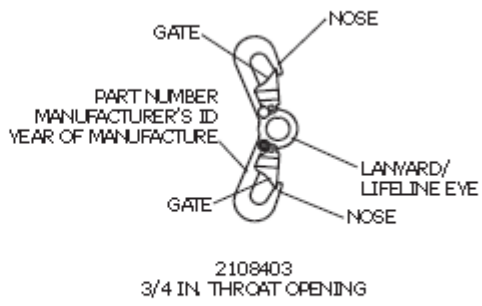
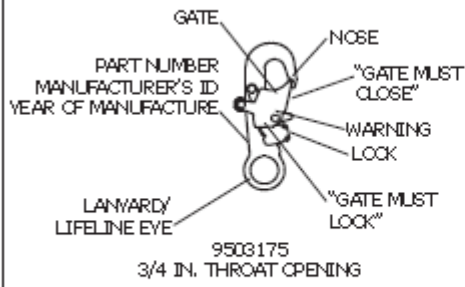

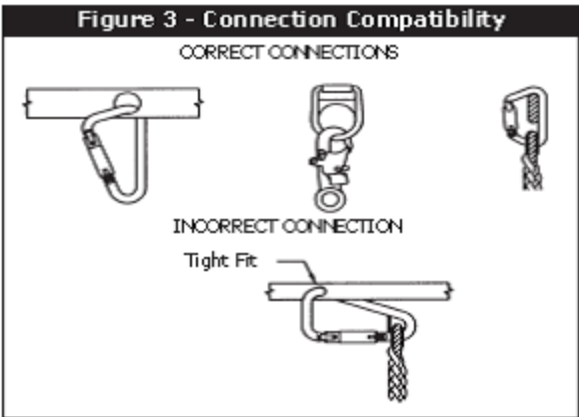
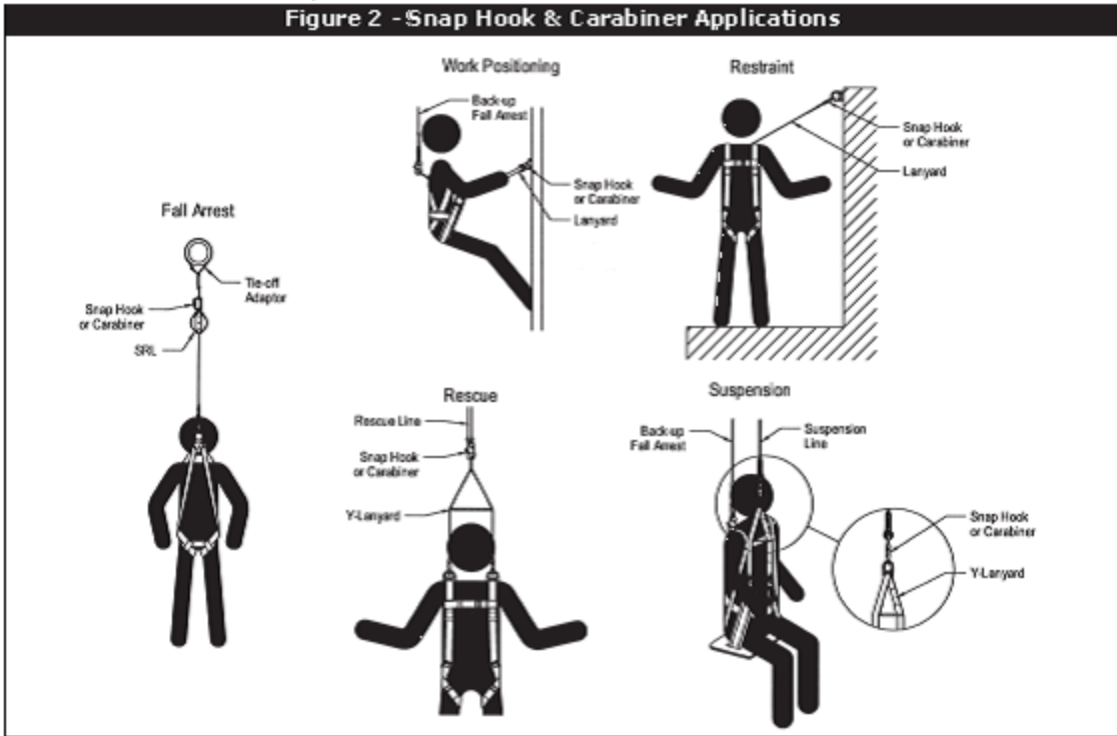
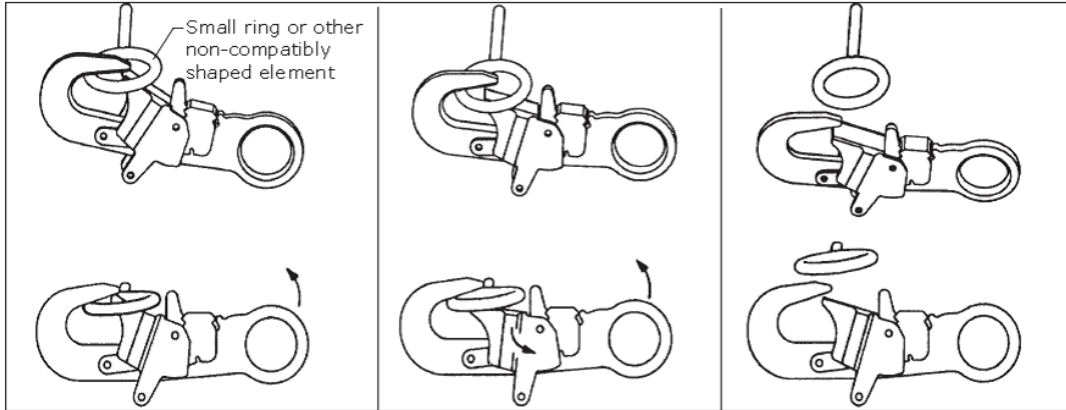

FIGURE 4 - Unintentional Disengagement (Roll-out)

If the connecting element that a snap hook (shown) or carabiner attaches to is undersized or irregular in shape, a situation could occur where the connecting element applies a force to the gate of the snap hook or carabiner. This force may cause the gate (of either a self-locking or a non-locking snap hook) to open, allowing the snap hook or carabiner to disengage from the connecting point. For ANSI Z359.1-2007 compliant hooks, there are no restrictions on the size or shape of the mating connector provided the snap hook is free to align with the applied load as intended.



1. Force is applied to the snap hook.

2. The gate presses against the connecting ring.

3. The gate opens allowing the snap hook to slip off.

FIGURE 5 - INAPPROPRIATE CONNECTIONS

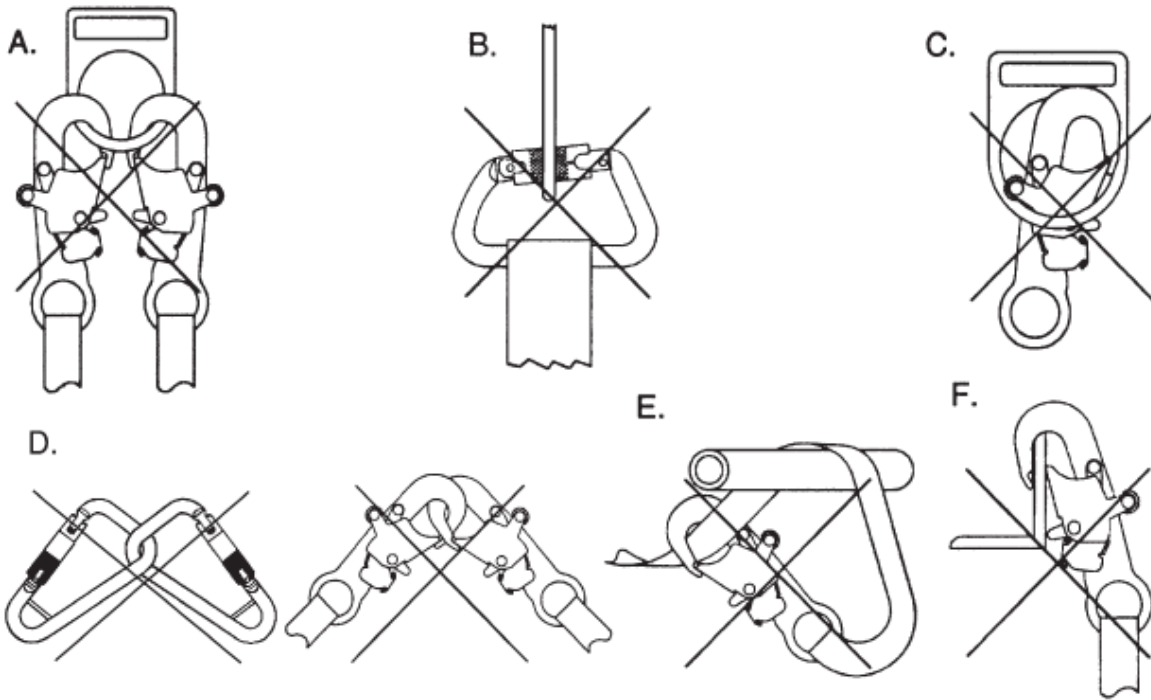

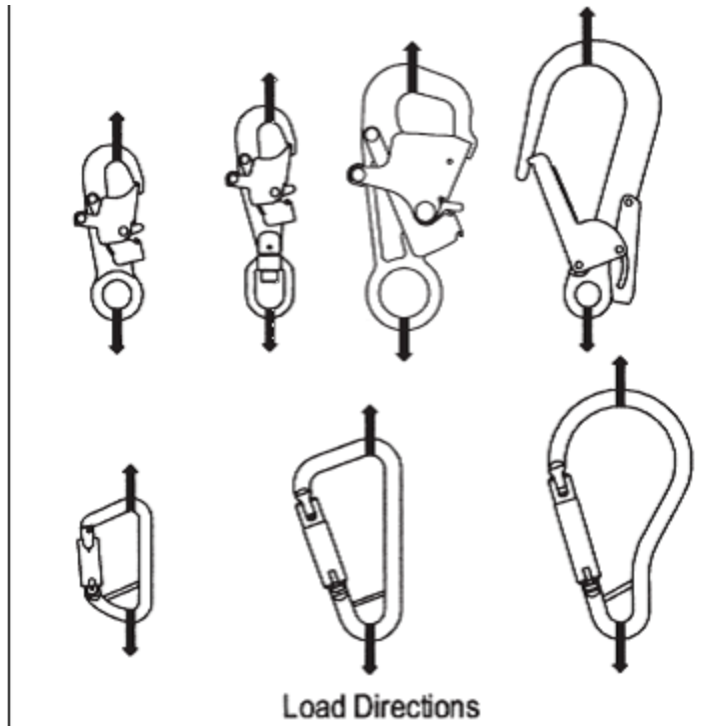

Anchor Points

- Anchor points shall be designed and installed under the supervision of a qualified person.
- Anchor points used to attach restraint systems shall be capable of supporting at least 800 pounds per person attached.
- Anchor points used to attach a positioning device system shall be capable of supporting at least 3,000 pounds.
- Anchor points used to attach personal fall arrest systems shall be capable of supporting at least 5,000 pounds per person attached.
- Permanent anchor points shall be labeled as to their design capacity.
- Anchor points must be properly inspected and maintained per manufactured recommendation. Tie-Off Adaptors/Anchor Plates Inspection Checklist is available in [Appendix E](#).

Requirements for Openings

Hole Covers, Wall Openings, and Skylights

An opening is a gap or void in a walking/working surface, platform, roof, wall, or floor which materials or a person can fall through or into.

- Construction Industry requirements: The opening is a gap or void 2 inches or more in its least dimension, in a floor, roof, or other walking/working surface.
- General Industrial requirements: The opening measuring less than 12 inches but more than 1 inch in its least dimension, in any floor, platform, pavement, or yard, through which materials but not persons may fall; such as a pipe opening or slot opening.

Hole Covers

- Covers located in traffic areas must be able to support at least twice the maximum axle load of the largest vehicle expected to cross over them.
- Other covers must be able to support at least twice the weight of employees, equipment, and materials that may be imposed on them.
- Covers must be secured to prevent accidental movement by wind, equipment, or employees.
- Temporary covers must be marked with the word "HOLE" or "COVER" to provide warning of the hazard.
- While the cover is not in place, the floor hole shall be constantly attended by someone or shall be protected by a standard railing.

Wall Openings

Working on, at, above, or near wall openings (including those with chutes attached) where the outside bottom edge of the wall opening is 6 feet or more above lower levels and the inside bottom edge of the wall opening is less than 39 inches above the walking/working surface, must be protected from falling by the use of either guardrail systems, restraint systems, or positioning device systems.

Skylights

If there is an exposure of falling through a skylight to a lower level, the skylight shall be guarded by a standard skylight screen or a fixed standard railing on all exposed sides or some other type of fall protection system or a fall protection plan must be used.

Appendices

- [Appendix A-Fall Protection Hazard Assessment Plan](#)
- [Appendix B-Fall Protection Rescue Plan](#)
- [Appendix C-Self Retracting Lifelines](#)
- [Appendix D-Dee-Rings, Hooks, and Carbiners Checklist](#)
- [Appendix E-Tip Off Adaptors and Anchorage Plate Checklist](#)
- [Appendix F-Full Body Harness Checklist](#)
- [Appendix G-Lanyard Inspection Checklist](#)
- [Appendix H-Scaffold Tags](#)
- [Appendix I-Roof Fall Protection Checklist](#)
- [Appendix J- Comprehensive Roof Fall Protection Assessment](#)